

Weigh the Difference...
Glass Breaker / Fines Removal System

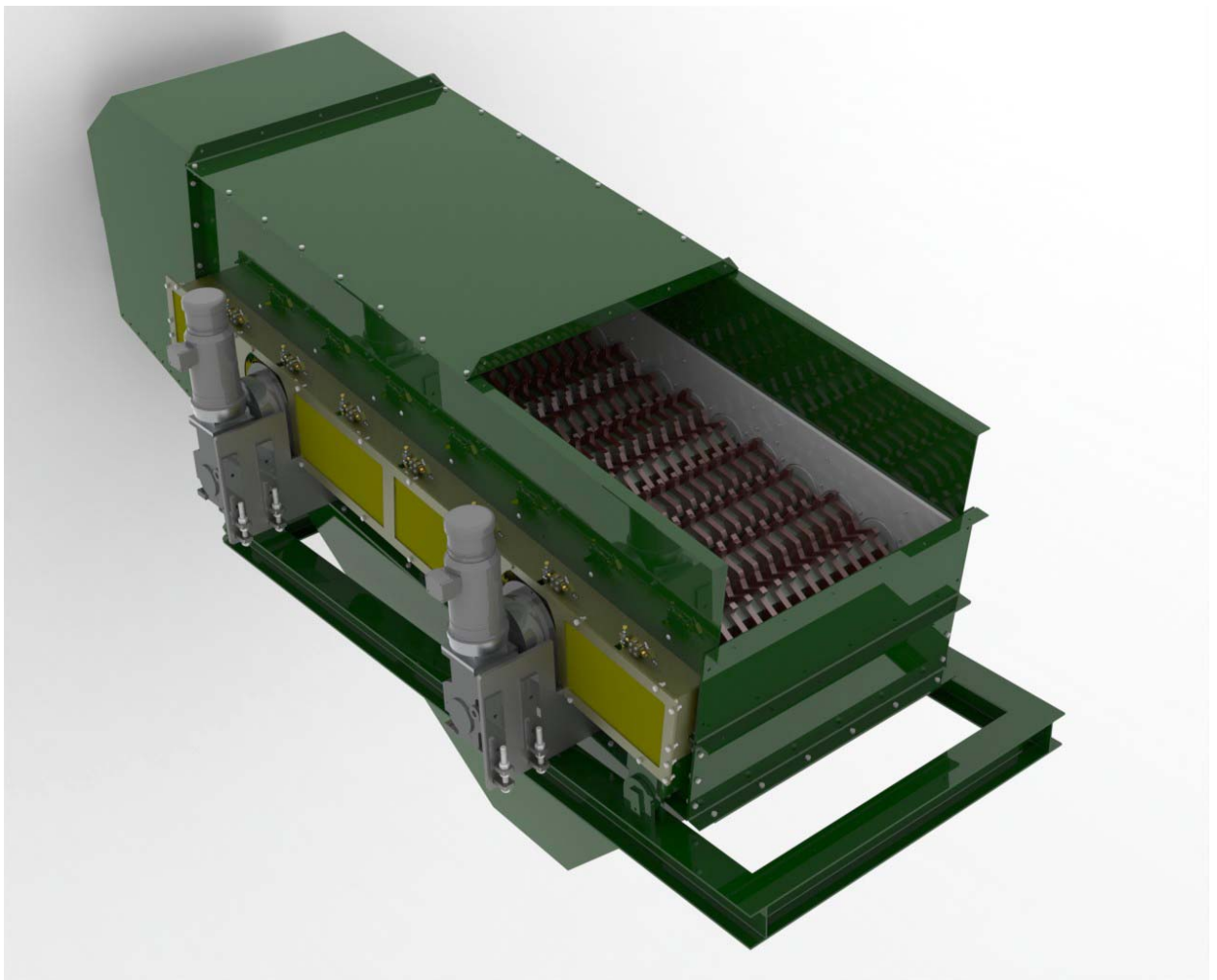

Patent Pending



5 Gigante Drive Hampstead, NH 03841 USA
TEL: (603) 329-7337 ~ WATTS: (877) 448-4443 ~ FAX: (603) 329-7458
www.greenmachinesales E-MAIL: sales@greenmachinesales.com

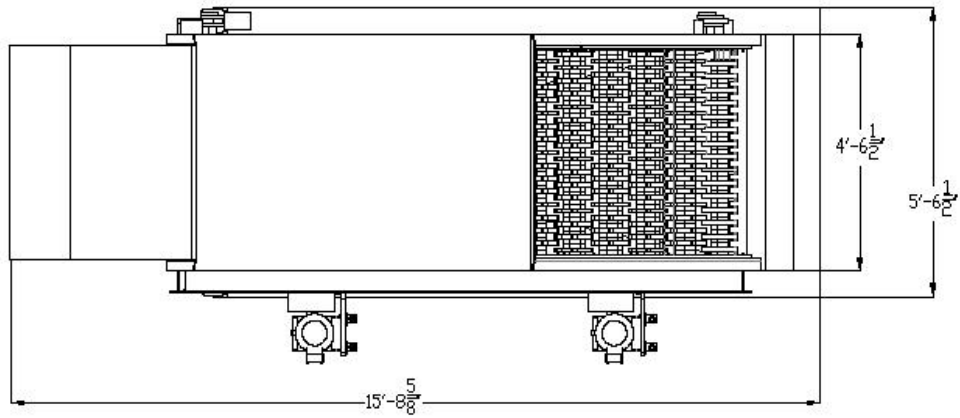

View: Model # FRS-66-15

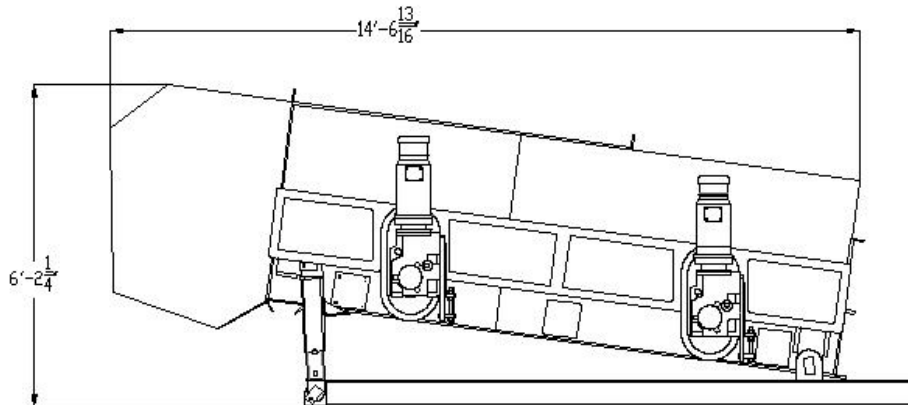

Application:	Designed to break and separate glass from other recycling containers and remove fines from C&D and other materials.
Screen width:	36" - 84" Wide Screen
Screen Length:	8' - 18' Long
Discs:	Steel star discs hardened to 500 brinell
Spacers:	Patent pend steel 500 brinell wrap resistant disc spacers
IFO:	5/8" x 2 1/4" to 1 1/2" x 2 1/2"
Shafts:	3" square shafts with replacable spindals.
Motors:	Multiple zone 5 - 7-1/2 HP TEFC energy efficient motors
Reducers:	Fixed mounted with belt drives.
Drives:	Variable frequency drives provided by others
Shaft Sprockets:	High wear with #160 chain
Angle:	0 - 12 degrees incline adjustment standard
Auto Lube:	Automatic oiler for drive chain, selinoid drived through manifold system.
Weight:	Approx. 6,000 to 24,000 pounds.
Supports:	Optional
Chutes:	Optional



5 Gigante Drive Hampstead, NH 03841 USA
 TEL: (603) 329-7337 ~ WATTS: (877) 448-4443 ~ FAX: (603) 329-7458
 WEB: www.greenmachinesales E-MAIL: sales@greenmachinesales.com