

# CONVEYOR APPLICATION SURVEY FORM

## “A” STYLE CONVEYOR

PROJECT NAME: \_\_\_\_\_ SELLERS NAME \_\_\_\_\_

DATE OF REQUEST: \_\_\_\_\_ RESPONSE DATE: \_\_\_\_\_ EST. ORDER DATE: \_\_\_\_\_

APPLICATION: FIBER \_\_\_ CO-MINGLE \_\_\_ NON-FERROUS \_\_\_ C&D \_\_\_ SOLID WASTE \_\_\_

BELT TYPE: 4" PITCH \_\_\_ 6" PITCH \_\_\_ 9" PITCH \_\_\_ STEEL \_\_\_ COMBOBELT \_\_\_

SLIDER BELT \_\_\_ APRON BELT \_\_\_ A-PAN BELT \_\_\_

**FRAME TYPE:**

CLOSED FRAME \_\_\_\_\_ CLOSED OPEN FRAME \_\_\_\_\_ OPEN FRAME \_\_\_\_\_

**FEED AREA:**

ABOVE FLOOR \_\_\_\_\_ BELOW FLOOR: \_\_\_\_\_ PIT LAYOUT NEEDED: \_\_\_\_\_

**PRE-EXISTING PIT DIMENSIONS:**

WIDTH \_\_\_\_\_ LENGTH \_\_\_\_\_ DEPTH \_\_\_\_\_

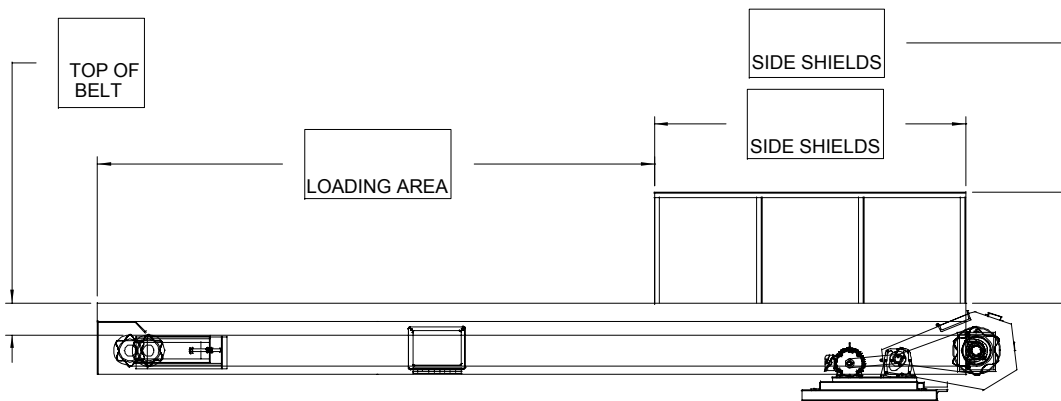
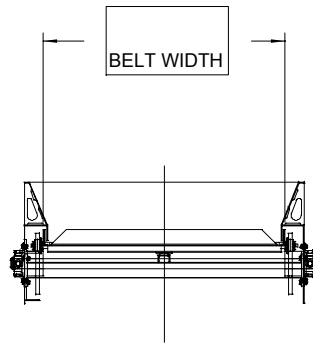

**COMMENTS:** \_\_\_\_\_  
 \_\_\_\_\_  
 \_\_\_\_\_

Submitted by: \_\_\_\_\_

Date submitted: \_\_\_\_\_